

# Pesticide Application

## Pesticide Safety

Pesticide safety begins with the selection of the pesticide to be purchased. Various considerations, including who is going to be exposed during and after application, ease of application, potential harm to the environment, toxicity of the pesticide, the pest to be controlled and the cost of the material, must be considered.

## Storage and Inventory

The first safety step is proper storage. Without proper storage, pesticides can be damaged due to weather or mechanical situations. Correct storage also decreases the chance of contamination between two different types of pesticides and decreases the chance of the wrong pesticide being used.

A good storage building should be constructed of nonflammable material. It should have a floor that will prohibit liquids and dry pesticides from penetrating and leaking through and yet provide for easy cleanup. The building should be well ventilated and lighted with temperature control to prevent freezing and excessive heat. All storage buildings should be well marked and locked. If possible, the building should be fenced to further keep unauthorized people away. The storage area should be supplied with detergent, hand cleaner and water; absorbent materials, such as absorbent clay, sawdust and paper to soak up spills; a shovel, broom and dustpan; and a fire extinguisher rated for ABC fires.

Inventory control includes obtaining a Material Safety Data Sheet (MSDS) for each pesticide stored and used. It is also good management to have a current label for each pesticide stored and used on the facility. Both the MSDS's and labels should be stored in location(s) that permit the workers and staff to easily obtain them at any hour. This usually means having duplicates of each MSDS and label and having two separate filing places. It is usually best to designate one or two persons to be responsible for inventory control.

## Applicator Safety

There are four areas of pesticide application that expose the pesticide user. The first is mixing/loading. Mixer/loaders must be aware that this is usually the most likely area for personal contamination to occur. Simple steps

can greatly reduce exposure during the operation. Proper equipment must be available for accurate mixing/loading operations. This includes, but is not limited to, proper measuring devices (containers/scales), hoses and cutoff valves, backflow valves and personal protective equipment (PPE).

The PPE can include a plastic apron, rubber or plastic gloves, rubber or plastic boots, arm protection (either with long-sleeve shirts or disposable sleeves), leg protection, face shield, hat, respirator and disposable coveralls. Not all the above PPE is needed for all pesticides, and some can be used in place of others. Disposable coveralls can replace the leg and arm protection and the need for an apron. Regular tightly woven coveralls can replace disposable ones for certain pesticides if they are washed after each day's use. PPE can be determined from the label and MSDS for each pesticide used. When using pesticide mixtures, select the PPE for the most hazardous pesticide. The mixers/loaders should be very aware of the fact that they **should not use leather or canvas gloves or boots**. These types of gloves and boots retain pesticide residues and cannot be cleaned.

The next area for safety is the application. Generally, the applicator should use the same PPE as the mixer/loader. Although most applications are made at times of low wind speeds and with booms that are not far from the ground, there is still a good potential for the applicator to be exposed to pesticide drift or vapors. Plus, the applicator will have available the necessary PPE in case the sprayer malfunctions.

Sprayer cleanup is the third area of safety concern. Persons cleaning the spray equipment should use the same PPE as the mixer/loader. The cleanup people should be extra aware of the initial rinse/wash water containing pesticides. This is more from the chronic toxicity standpoint than from the acute. They should be especially wary about walking around in water without proper foot protection.

The last segment of applicator safety is personal cleanup. Each person should always clean up before eating, smoking or using the bathroom. They should also shower after working with pesticides, preferably right after the job is completed or at the end of the day. Their clothes are to be laundered separately from the family clothes.

Before laundering, it is helpful to rinse the clothes by hanging them on a line and hosing them down with water. This gets a fair amount of pesticide out of the clothes before washing. Then one should use hot (140°F) water and a strong detergent with a 12-minute wash cycle. After the wash is finished, remove the clothes and run another wash cycle to “rinse” the washer. All clothes used for pesticide applications should be air-dried. Do not dry the clothes in a dryer because there is a chance of some pesticide residue being left on the dryer drum.

## Turfgrass User Safety

Whenever possible, pesticide applications to turfgrass areas should be applied to provide the maximum amount of time from application to use of the turf. This translates into not allowing access to treated areas until the sprays have dried or for 24 hours. Never spray a turf area and then permit people or pets to have immediate access.

One must realize that users of turfgrass areas will be doing things (picnicking, walking, sunbathing) that increase their exposure. The clothing worn by turfgrass users is not conducive to reducing chronic exposure. Their leather or canvas shoes can retain pesticide residues if they walk in areas that have been recently treated with pesticides. The residues are not easily removed; therefore, the users can get a small dose every time the shoes are worn. Likewise, persons going barefoot or sunbathing can come into direct contact with spray residues. Children often have direct contact with the grass. Therefore, do not permit access to areas that have been treated with pesticides until the sprays have dried or 24 hours has elapsed, whichever is specified on the pesticide label.

## Wildlife Safety

The use of pesticides on turfgrass must also take into consideration possible impact on wildlife. Many pesticides are toxic to fish and/or wildlife. Therefore, do not spray pesticides in or on water or under situations that can lead to fish and/or wildlife kills. Also, be careful that pesticides are not applied just before a thunderstorm or irrigation schedule. You do not want to wash the pesticide into the water system.

Many parks and golf courses have creeks and waterways. One must be careful in the selection and use of pesticides in these aquatic areas. The applicator must also be careful not to

permit sprays to drift or be carried into water that may be near the turf area.

## Summary

Both the turfgrass manager and the user of the turfgrass should be aware of the benefits and risks involved with pesticides. The immediate risks are from acute toxicity. If the mixer/loader, applicator and cleanup person use proper PPE and techniques, their risks are greatly reduced. The user of the turf area is at the “mercy” of the turfgrass manager. Once again, if the turfgrass manager has taken the proper steps, the risk to the turfgrass user is also greatly reduced. The chronic risk for each party is more difficult to determine. By using proper application techniques and PPE, the turfgrass manager will reduce the chronic toxicity problems to the workers. Likewise, if the turfgrass manager has taken proper steps during and after application of pesticides, then the chronic risks to the turfgrass users should be reduced.

These are just a few items for turf managers to be aware of when using pesticides. Responsibility does not stop with the production of turf – it goes to the persons using that turf.

## Pesticide Laws and Regulations

There are many federal and state laws that regulate the use of pesticides. These laws must be followed to the best of your ability to insure the proper results and protect people and the environment from unnecessary dangers and contamination. The best way to meet most of these regulations is to follow the directions on the pesticide label. The label in itself is a “law,” and all directions on the label are to be followed. To do differently is to be in violation of the label and the law.

The state of Arkansas requires all persons purchasing and/or applying a restricted-use pesticide to be certified applicators. For turfgrass managers, they would be certified in the Ornamental and Turf category. Study material may be obtained from your local Cooperative Extension Service office, and testing is conducted by the Arkansas State Plant Board. Persons certified as commercial or noncommercial applicators are required to keep records of all pesticide applications. These records are to be kept at the office of the business for a minimum of 2 years. The records should contain the following: time and place of each application,

name of applicators, legal land description, date used, tank mix, dilution rate (rate of carrier), quantity used, complete trade name and registration number of product used, target pest and use site.

There are several other laws and regulations that may affect a turfgrass manager. One should check with the Arkansas State Plant Board, Arkansas Department of Labor, Arkansas Department of Health and local authorities to determine other regulations that may affect your business.

## **SARA, Title III, or Community Right-to-Know**

SARA stipulates that anyone who has specific hazardous materials above a certain quantity on their facility must report the storage of those materials to the State Emergency Response Committee (SERC) and to the Local Emergency Planning Committee (LEPC). A list of the chemicals that must be reported can be obtained from your local Cooperative Extension Service office. One should check with their LEPC on the various requirements of the Act for the business. This Act requires those who fall under it to develop an emergency response plan for accidents. This plan can be developed in conjunction with your LEPC. This is an area where a good storage inventory program will greatly assist the turfgrass manager.

## **Disposal**

This is the most unclear aspect of pesticide application. Disposal of metal, glass and plastic containers can best be handled by triple rinsing and pouring the rinsate into the spray tank. These containers can then be disposed of in a permitted landfill. For paper bags, empty their contents into the spray tank, and then cut the sack so that the remaining material can be “shaken” into the tank. These bags can then be disposed of in the trash or taken to a permitted landfill. Some landfills have local ordinances against disposing pesticide containers even if they are properly rinsed or cleaned, so check your local situation.

Disposal of excess pesticide tank mix material and water used for cleaning spray equipment is a very difficult problem. Presently, the only thing anyone will agree on is to apply excess tank mix and/or water used for cleaning spray equipment to sites that are listed on the pesticide label. This would include the sites just sprayed or similar areas.

## **Environmental Factors Affecting Pesticide Effectiveness**

Many factors determine the effectiveness of a pesticide program. Using the right pesticide and applying it correctly are the most important factors that determine the final outcome. However, there are some environmental factors that can have a negative or positive effect on pesticides. Environmental factors that affect pesticides can be divided into three (3) groups: climatic, plant and soil factors.

### **Climatic Factors**

Temperature affects the amount of time required for a pesticide to do its job. For example, when air temperatures are between 65°F to 85°F, a plant is rapidly growing and herbicides will be more effective. Long periods of cold or hot temperatures will slow down herbicide activity.

High humidity allows foliar-applied pesticides to enter a plant quicker than at low humidity. During a period of high humidity and moderate temperature is the optimum time to spray a pesticide that must be taken up by plant foliage.

Precipitation soon after a pesticide application may help or hurt the final results. A moderate (1 inch or less) rain just after a soil-applied preemergence herbicide or soil insecticide will move the product down into the soil where it is needed. A rain shortly after an application of a foliar-applied herbicide or systemic fungicide will drastically reduce the level of control. Any pesticide that needs to be taken up through the turf foliage should not be applied if there is a good chance of rain within a few hours. The decision not to spray because of the possibility of rain must be made by the applicator.

Wind is definitely the most important climatic factor. Excessive wind does not have a direct effect on pesticide effectiveness; however, indirectly it is a major problem. Excessive wind (greater than 10 mph) distorts spray patterns and hinders the application of the pesticide. Using a drift control additive will help, but knowing when not to spray because of excessive winds is more important. Applying pesticides in the early morning or late evening hours may help avoid the more windy parts of the day.

## Plant Factors

For several pesticides, it may be necessary for them to enter the plant through the leaf surface (foliar-applied). The cuticle and wax on the surface of a leaf is a barrier the pesticide must cross before it can enter the leaf. Older plants or plants under stress will tend to have thickened, waxy layers making the leaves harder to penetrate. It may be necessary to use a crop oil if you are making late season applications. Also, on the leaf surface of certain plants there may be an abundance of leaf hairs. Spray droplets tend to stand up on the hairs and do not contact the leaf surface. The addition of a surfactant to the spray mix would help the spray droplet penetrate the hairs and allow the pesticide to come in contact with the leaf surface.

An important plant factor that influences herbicides is the growth pattern and growth stage of the plant. Each year weeds complete four stages of growth: (1) seedling, (2) vegetative, (3) seed production, and (4) maturity. Annual and biennial plants are easiest to control at the seedling stage, but perennial plants can be more effectively controlled during their vegetative stage. Treating perennial plants at this stage allows for better control of the underground parts of the plant.

Location of growing points on a plant can affect their level of control. Applying an herbicide directly to the growing point will generally increase the effectiveness of the herbicide. A grassy weed has its growing point(s) below the soil surface that makes it difficult to apply an herbicide directly to the growing point. A broadleaf weed has an exposed growing point at the top of the plant and along leaf axils. Herbicides can be applied directly to growing points on broadleaf plants.

## Soil Factors

The texture and organic matter content of a soil has a definite effect on soil-applied pesticides. Soil texture depends on the percent of sand, silt and clay. Soils high in clay content will tie up or adsorb soil pesticide particles, making them unavailable for effective pest control. Higher pesticide rates may be recommended on fine-textured clay soils. Sandy or silty soils do not adsorb very much of the pesticides, making them more available for pest control. Lower rates of soil-applied pesticide can be used on coarse-textured sandy soils without sacrificing pest control (check the label for range of rates).

Arkansas has a wide variety of soil textures which range from very fine-textured clay soils to very coarse textured sandy soils. Erratic pest control from a successful application of a soil-applied pesticide could very likely be attributed to the texture of the soil.

Soil organic matter content also has a dramatic effect on soil-applied pesticides, especially on organic products. Soils with 2 percent organic matter content or greater will require higher pesticide rates for successful pest control (check label for range of rates). High organic matter soils have a greater potential to tie up pesticides than any other soil factor. Most Arkansas soils have less than 3 percent organic matter.

Another factor that can affect a soil-applied pesticide is the pH of the soil. Some pesticides will be less effective in soils with a low pH (less than 6.0), while others are relatively unaffected by soil pH.

Pesticides can also be affected by the pH of the water that is used for mixing. Few Arkansas water sources contain what is termed "hard water." Hard water has an overabundance of calcium, magnesium and many other elements which increase the pH of the water. Mixing certain pesticides with water that has a high pH (8.0 or higher) can reduce their effectiveness. If applications of a pesticide have been producing erratic results in the past, it would be worth the time to check the pH of the water source. Since pH levels of any given water source fluctuate during the year, a pH reading should be taken as near to application time (month of application) as possible. If the water source has a pH level of 8.0 or higher, then a buffer should be added to each tank of water to lower the pH.

## Application Equipment

### Liquid Application

Most common pesticides are applied in a liquid form. They may be distributed as a liquid or powder, but are mixed with water, oil or some other liquid carrier for application. Some fertilizers also are applied as liquids, so liquid application equipment has long been the standard for pesticide and fertilizer application. This equipment generally consists of several different types of boom and boomless (or broadcast) sprayers, which have unique characteristics.

## Boom Sprayers

Boom sprayers are sprayers which have nozzles arranged along a boom for uniform distribution of material. They vary in size, depending on the type of use. Some agricultural sprayers may have boom widths of 60 feet to 80 feet, while hand-held or push type booms may be only 1 foot to 4 feet wide. When properly adjusted and calibrated, each type of sprayer can provide uniform coverage.

Turfgrass managers typically use boom sprayers on flat surfaces, such as fairways and greens. Large open areas, such as practice areas or wide fairways, can be sprayed with wide booms with little problem, but wide booms are difficult to maneuver in tight areas. If terrain is uneven, a shorter boom width is recommended for the best distribution.

## Boomless Sprayers

Boomless or broadcast sprayers are essentially the same as boom sprayers, except a single jet or multiple jet cluster nozzle replaces the boom. Boomless nozzles can be used to spray widths up to 40 feet. However, spraying wide swaths from a single nozzle makes uniform coverage difficult to obtain. Boomless sprayers are also extremely susceptible to drift, especially when operating at pressures over 40 psi. Boomless sprayers are not recommended for use on fairways and other areas where uniform coverage is needed. They are best suited for areas where boom sprayers are difficult to use, such as rough terrain, areas with many trees, fencerows and roadsides.

Spray guns, whether operated from manual (backpack) or powered sprayers, are another type of boomless sprayer. They are primarily used for ornamental plants and are not recommended for use on turf grass except for spraying areas less than 10 or 20 square feet. Operators should use boom sprayers with conventional nozzles whenever possible. Spray guns should only be used around shrubs, trees and areas where it is not feasible to use hand-held or push type booms. Spray gun operators should strive for uniform coverage.

## Nozzle Types

Nozzle selection is one of the most important decisions relating to pesticide application. Nozzle type determines not only the amount of spray applied to a particular area but also the uniformity of the applied spray, the coverage obtained on the sprayed surfaces and the amount of drift that can occur. Each nozzle type

has specific characteristics and capabilities and is designed for use under certain application conditions. Regular flat-fan, flooding flat-fan and boomless nozzle types are commonly used for ground application of turf chemicals.

Regular flat-fan nozzles are used for most broadcast spraying of herbicides and for certain insecticides when foliar penetration and coverage are not required. These nozzles produce a flat oval spray pattern with tapered edges. They are available in various standard spray fan angles and are usually spaced 20 inches apart on the boom at a height range of 10 to 23 inches.

Recommended boom heights for standard spray angles are:

Spray Angle (degrees)	Boom Height for 20 Inch Spacing (inches)
65	21-23
73	20-22
80	17-19
110	10-12

The normal recommended operating pressure range for regular flat-fan nozzles is 15 psi to 30 psi. In this range, this nozzle type will produce medium to coarse drops that are less susceptible to drift than finer drops produced at pressures of 40 psi or greater. Regular flat-fan nozzles (**Figure 2.7.1**) are also recommended for some foliar-applied herbicides and fungicides at pressures of 40 psi to 60 psi. These high pressures will generate finer drops for maximum coverage on the plant surface, but the possibility of drift increases significantly, so appropriate precautions must be taken to minimize its effects.

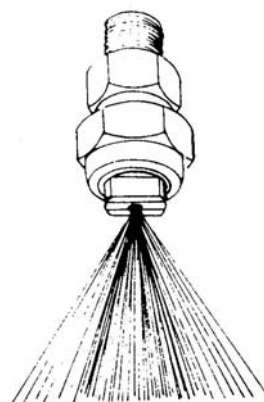

**Figure 2.7.1. Regular flat fan.**

Because the outer edges of the spray patterns of these nozzles have tapered or reduced volumes, nozzles must be carefully aligned and at the proper height so adjacent patterns along the boom will overlap to obtain uniform coverage (**Figure 2.7.2**). The most effective pattern is achieved when this overlap is 30 percent to 50 percent of the nozzle spacing. Because of their ability to produce a very uniform pattern when correctly overlapped, the regular flat-fan nozzle is generally the best choice for the broadcast application of herbicides.

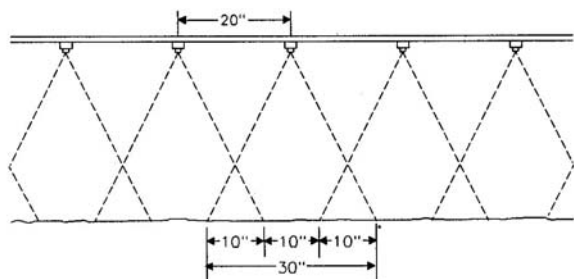

**Figure 2.7.2. Fifty percent overlap.**

LP or “low-pressure” flat-fan nozzles are available from the Spraying Systems Company. This nozzle develops a normal fan angle and distribution pattern at spray pressures from 10 psi to 25 psi. Operating at a lower pressure results in larger drops and less drift than the regular flat-fan nozzle designed to operate at pressures of 15 psi to 30 psi.

Flooding flat-fan nozzles produce a wide-angle, flat-fan pattern and are commonly used for applying herbicides and mixtures of herbicides and liquid fertilizers (**Figure 2.7.3**). The nozzle spacing on the boom for applying herbicides and fertilizers is generally 40 inches. These nozzles should be operated within a pressure range of 8 psi to 25 psi for maximum effectiveness and drift control. Changes in pressure will affect the width of the spray pattern more with this type of nozzle than with regular flat-fan nozzles. Also, the distribution pattern is usually not as uniform as that of a regular flat-fan tip. The most effective pattern is achieved when the nozzle is mounted at a height and angle to obtain at least double coverage or 100 percent overlap (**Figure 2.7.4**).

Flooding nozzles can be mounted so that they spray straight down, straight back or at any angle in between. However, the most uniform coverage is obtained when the nozzle is oriented to spray at about 45 percent above the horizontal.

The flooding flat-fan nozzle is the best choice for applying a liquid fertilizer or a liquid

fertilizer-herbicide mixture. Due to large droplet size, they are effective when applying straight herbicides in situations where drift is a problem. However, they do not produce as uniform a pattern as regular flat-fan nozzles. Regular flat-fan nozzles operated at low pressures (10 to 15 psi) should be used when drift is a problem and precise uniform coverage is required.

## Nozzle Material

Nozzle tips are available in a wide variety of materials, including ceramic, hardened stainless steel, stainless steel, nylon and brass. Ceramic and hardened stainless steel are the most wear-resistant materials, but are also the most expensive. Both stainless steel and ceramic tips have excellent wear resistance with either corrosive or abrasive materials. Ceramic tips are more susceptible to breakage and are used less than stainless steel tips. Ceramic and stainless steel tips wear uniformly so gradual pressure reduction during calibration will allow extended nozzle life.

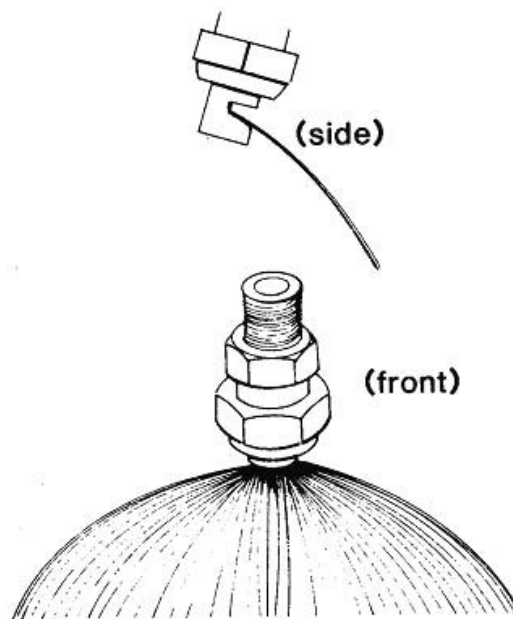

**Figure 2.7.3. Flooding flat fan.**

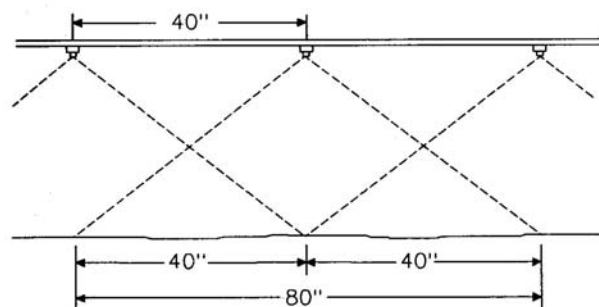

**Figure 2.7.4. 100 percent overlap.**

Nylon tips are also very resistance to corrosion and abrasion. They are, however, subject to swelling when exposed to some solvents. Brass tips are the most common but wear rapidly and less uniformly due to variations in material hardness when used with abrasive materials such as wettable powders; they also corrode easily with some liquid fertilizers. As brass nozzles wear or corrode, the orifice size changes, making calibration tables for these nozzles inaccurate. Each nozzle will wear or corrode at different rates, making it difficult to maintain boom spray uniformity or calibration. Wear and corrosion may also alter the spray pattern of nozzles. Brass tips are only economic when used on sprayers with very low annual use. For sprayers that have more extensive use, stainless steel or nylon tips are a better choice because of their longer wear life and uniformity of wear.

## Calibration

Calibration is the process of adjusting spray equipment to uniformly apply the desired rate of chemical. The performance of any chemical depends upon the proper application of the correct amount on a given area. Most chemical performance complaints can usually be traced to errors in mixing or applying the chemical. The purpose of calibration is to ensure that the sprayer is applying the chemical uniformly and at the correct rate.

### Variables Affecting Application Rate –

Three variables affect the amount of chemical mixture applied per acre:

1. The nozzle flow rate
2. The ground speed of the sprayer
3. The effective sprayed width per nozzle

To calibrate a sprayer accurately, the effect of each of these variables on sprayer output must be understood and controlled.

**Nozzle Flow Rate** – The flow rate through the nozzle varies with orifice tip size and nozzle pressure. Installing nozzles with a larger or smaller orifice size is the most effective way to change the sprayer's output if major volume changes are required.

Changes in nozzle pressure should be used for minor increases or decreases of sprayer output, since pressure changes have significantly less effect than nozzle changes. It takes a fourfold increase in pressure to double nozzle flow rate. For example, to increase nozzle flow rate from 25 GPM at 20 psi to 0.50 GPM,

pressure would have to be increased to 80 psi (4 x 20). Decreasing nozzle pressure can be used effectively to maintain an application rate due to nozzle wear. It should never be used to make major changes. Most nozzles work best at pressures between 20 psi to 40 psi. Lower pressures may distort the spray pattern, while higher pressures increase spray drift.

**Ground Speed** – The spray application rate varies inversely with the ground speed. Doubling the ground speed of a sprayer reduces the gallons of spray applied per acre (GPA) by one-half. For example, a sprayer applying 20 GPA at 3 mph would apply only 10 GPA at a speed of 6 mph if all other factors remained the same. A sprayer calibrated at 4 mph, but actually operated at 3 mph, will overspray by 33 percent and significantly increase chemical costs and the potential for turf damage.

**Sprayed Width Per Nozzle** – The effective width sprayed per nozzle also affects the spray application rate. Doubling the effective sprayed width per nozzle will decrease the gallons per acre (GPA) applied by one-half. For example, if the nozzle is applying 40 GPA on a 20-inch spacing, a change to a 40-inch spacing will decrease the application rate to 20 GPA.

## Precalibration Checks

Before calibrating a sprayer, service the entire unit, check for uniform nozzle output and pattern, and determine exactly how much liquid your sprayer tank holds.

**Servicing** – Clean all lines and strainers, making sure the strainers are in good condition and are the correct size for the type of chemical formulation that is to be applied. Inspect all hoses for signs of aging, damage or leaks and hose clamps for corrosion and adjustment. Check the pressure gauge to determine if it is working properly (is the pressure holding constant and does it read zero when the pump is shut off?). The actual accuracy of the gauge is not as important as its ability to give the same pressure reading each time it is produced. At least once a year, preferably at the beginning of the spraying season, check the gauge against another gauge that is known to be accurate. Also, boom pressure will be lower than remote-mounted gauge pressure. To determine pressure loss, operate the sprayer at a known pressure, then install a gauge on one of the nozzle outlets on the boom and record the lower pressure. Check nozzle pressure at several operating pressures to develop a nozzle pressure table.

**Nozzle Output and Pattern** – Check for uniformity of nozzle output and for consistency of spray angles, spacing and height. To check for uniform nozzle output, install the selected nozzle tips, partially fill the spray tank with clean water and operate the sprayer at a pressure within the recommended range. Place a container (for example, a quart jar) under each nozzle and check to see whether all the jars fill in about the same time. Inexpensive calibration flow meters are available for direct readings of individual nozzle flow rates as a method to quickly check nozzle calibration. Replace any nozzle tips that have an output that varies more than 5 percent from the output of the rest of the tips or has an obviously different fan angle or distorted spray pattern. An effective way to determine whether a uniform pattern is being produced and whether the boom is at the proper height is to spray some water on a warm, dry surface, like a paved road or gravel drive, and observe the drying pattern. If the pattern is not uniform, some strips or areas will dry slower than others.

**Tank Capacity** – Knowing the exact capacity of your sprayer's tank is necessary for accurate mixing of chemicals in the tank. The use of an inaccurate tank capacity when determining application rates is a common cause of under and over application. A tank thought to hold 200 gallons but which actually holds 250 gallons results in a built-in calibration error of 25 percent.

The best and easiest way to accurately determine tank capacity is to fill the tank using any convenient container for which an exact capacity is known. If container capacity is unknown, it can be determined by filling the container with water and then checking its weight (water weighs 8.33 pounds per gallon). Another effective way of measuring tank capacity is with an accurate flow meter. Flow meters should be checked for accuracy by weighing sample volumes taken over a given amount of time.

## Measuring Ground Speed

To apply chemicals accurately, ground speed must be constant. Field conditions such as surface roughness, softness and slopes will all affect ground speed and significantly change application rates. Speedometers and tachometers are generally not a good means of determining ground speed as wheel slippage can result in speedometer reading errors of 25 percent or more. Changes in tire size can also affect speedometer readings. The most accurate way

to maintain a constant ground speed is with a special sprayer speedometer that is run off a nondriven ground wheel. These speedometers are available from a number of spray equipment manufacturers and are a good investment if a considerable amount of spraying is done. Some sprayer monitors have the ability to accurately measure ground speed.

If an accurate speedometer is not available, the next best method to establish a calibrated ground speed is to measure the speed of the sprayer at a variety of throttle and gear settings in an area that has surface conditions like those of the turf to be sprayed. To measure ground speed, stake out a known distance in the turf. Suggested distances are 100 feet for speeds up to 5 mph, 200 feet for speeds from 5 mph to 10 mph and at least 300 feet for speeds above 10 mph. At the throttle setting and gear to be used during spraying, determine the travel time between the measured stakes in each direction. To ensure the greatest accuracy, the sprayer should be at least half full of liquid. Average the two speeds and use the following equation to determine the ground speed.

$$\text{Speed (mph)} = d/t \times 0.682$$

"d" is the distance between the two stakes, in feet.

"t" is average time it took to drive between the stakes, in seconds.

The number, 0.682, converts feet per second into mph.

## Determining Sprayer Output

There are a number of ways to determine sprayer output. One of the easiest and most effective methods is the nozzle output method. The advantage of this method is that it is done with the sprayer stationary. In order to use this method, three pieces of information must be known:

**Operating Pressure** – This will generally be in the 20 psi to 40 psi range depending on the type of nozzle used.

**Ground Speed** – This speed will normally be in the 3 mph to 8 mph range depending upon conditions of the area to be sprayed.

**Sprayed Width Per Nozzle** – Varies with the type of nozzle arrangement used but effectively is the spacing between nozzles on the boom.

To calibrate a sprayer using this method, follow these steps.

**Step 1.** Fill the sprayer partially with water and operate it at the correct pressure. Use a container marked in ounces to collect the output of a nozzle for 1 minute or some

convenient fraction of a minute. Check all nozzles to determine the average number of ounces per minute (OPM) of output for each nozzle and for wear uniformity comparisons (very important for brass nozzles spraying wettable powders).

**Step 2.** Convert the OPM determined in step 1 to gallons per minute (GPM) by dividing the OPM by 128 (the number of ounces in 1 gallon).

**Step 3.** Select the ground speed (mph) at which the sprayer will operate, normally 3 mph to 8 mph.

**Step 4.** Determine the sprayed width per nozzle (W), in inches. For broadcast spraying, “W” will equal the distance between nozzles.

**Step 5.** Once these values are known, the sprayer’s output in gallons per acre (GPA) can be calculated using the following equation:

$$\text{GPA} = \frac{\text{GPM} \times 5,940}{\text{MPH} \times \text{W}}$$

“GPA” is the sprayer’s output in gallons per acre.

“GPM” is the nozzle output determined in Step 2.

“5,940” is a constant used to convert inches, gallons per minute and miles per hour to gallons per acre.

“MPH” is the ground speed selected in Step 3.

“W” is the sprayed width in inches per nozzle that was determined in Step 4.

**Example:** A sprayer is set up to broadcast spray an herbicide with regular flat fan nozzles spaced 20 inches on center. A ground speed of 5 mph has been selected. The average collected nozzle output is 54 OPM.

What is the application rate in gallons per acre?

$$\text{GPM} = \frac{54}{128} = 0.42 \quad (\text{Step 2})$$

$$\text{GPA} = \frac{0.42 \times 5,940}{5 \times 20} = 24.94 \quad (\text{Step 5})$$

Under this set of conditions, the sprayer will apply approximately 25 gallons per acre. If this is not the application rate desired, then one or more conditions will need to be changed. If only a small change is needed, this can generally be accomplished by either raising or lowering the pressure. Remember to stay within the pressure limitations of the nozzle being used. If a larger change is required, change ground speed or switch to larger or smaller nozzle tips.

## Calibration Jars

Calibration jars are available which further simplify the calibration process. These jars

require that the following basic information be known or measured: pressure, ground speed, nozzle output and effective spray width per nozzle. They do, however, eliminate calculations involved by use of graduated charts on the calibration jars. Calibration jars are available from a number of sources and are effective when used according to the instructions that accompany them.

## Determining How Much Chemical To Put In Tank

To determine the amount of pesticide to add to the spray tank, the following must be known:

1. Recommended application rate of pesticide, from product label
2. Sprayer tank capacity
3. Calibrated sprayer output

A key concern here is to know the exact tank capacity. The recommended application rate of the pesticide is given on the label. The rate is usually indicated as pounds of total product per acre for wettable powders, and pints, quarts or gallons per acre for liquids. Sometimes the recommendation is given as pounds of active ingredient (lbs. a.i.) per acre rather than the amount of total product per acre. The active ingredient must be converted to actual product.

## Dry Formulation

**Example:** A pesticide recommendation calls for 2 pounds of active ingredient (a.i.) per acre. An 80 percent wettable powder has been purchased. The sprayer has a 200-gallon tank and is calibrated to apply 40 gallons per acre. How much pesticide should be added to the spray tank?

**Step 1.** Determine the number of acres that can be sprayed with each tank full. The sprayer has a 200-gallon tank and is calibrated to apply 40 gallons per acre (200/40 = 5 acres per tank).

**Step 2.** Determine the pounds of pesticide product needed per acre. Because not all of the product in the bag is an active ingredient, more than 2 pounds of the total product must be added for each “acre’s worth” of water in the tank. To determine how much more, divide the amount of active ingredient needed per acre (2 pounds) by the percent of active ingredients in the product (80%, which equals 0.80).

Two and one-half (2.5) pounds of product (2 pounds a.i./0.80 = 2.5 pounds) will be needed for each “acre’s worth” of water in the tank to apply 2 pounds of active ingredient per acre.

**Step 3.** Determine the amount of pesticide to add to each tank full. With each tank full, 5 acres will be sprayed (Step 1), and 2.5 pounds of product per acre are required (Step 2); therefore, 12.5 pounds (5 acres x 2.5 pounds/acre = 12.5 pounds) of product will need to be added to each tank full to obtain the desired application rate.

## Liquid Formulation

**Example:** A pesticide recommendation calls for 1 pound of active ingredient (a.i.) per acre. A pesticide that has 4 pounds of active ingredient per gallon has been purchased. The sprayer has a 150-gallon tank and is calibrated at 30 gallons per acre. How much pesticide should be added to the spray tank?

**Step 1.** Determine the number of acres that can be sprayed with each tank full. The sprayer has a 150-gallon tank and is calibrated for 30 gallons per acre ( $150/30 = 5$  acres per tank).

**Step 2.** Determine the amount of product needed per acre by dividing the recommended a.i. per acre by the concentration of the formulation. To apply 1 pound of active ingredient (a.i.) per acre, one-fourth gallon or 1 quart of product is needed for each “acre’s worth” of water in the tank ( $1 \text{ lb./acre} \times 4 \text{ lbs./gallon} = 0.25 \text{ gallons/acre}$ ).

**Step 3.** Determine the amount of pesticide to add to each tank full. With each tank full, 5 acres will be sprayed (Step 1), and 0.25 gallon (1 quart) of product per acre is required (Step 2). Add 5 quarts (5 acres x 1 quart per acre = 5 quarts) of pesticide to each tank full.

## Granular Application

Granular application equipment is traditionally used to apply fertilizers, but many pesticides are now available in granular form. Application equipment for granular pesticides is somewhat different than that for fertilizers because the volume of material applied is usually considerably less and uniform distribution is very important.

## Equipment

Granular application equipment consists of drop, rotary and air spreaders. All of these consist of a hopper and some type of metering device. Granules are metered through orifices in the bottom of drop spreaders and fall directly to the ground. Since granules drop straight down,

there is little chance for drift, and distribution is more uniform. Drop spreaders usually have narrow widths and are not recommended for large areas. Also, since particles fall straight down, the edge of the pattern is well defined, and small steering errors will cause areas to be missed or doubled.

Rotary or centrifugal spreaders are the most common granular applicators. They are available in hand-powered or tractor-powered models. With this type of spreader, granules are metered through an orifice onto a rotating disk. Granules are deflected off of the disk into an approximate half circle pattern. Because granules are thrown away from the spreader, wider swaths can be attained and large areas can be covered quickly. The pattern is feathered on the edges, so steering errors are less critical.

Air spreaders are popular in the agricultural market but are just now beginning to receive attention from turfgrass managers (**Figure 2.7.5**). Air spreaders meter granules through an orifice, or with a fluted roller, into a venturi cup where they are suspended in an airstream and travel through hoses to deflectors mounted on a boom. At the deflectors, the granules are distributed in a pattern similar to that of a flat fan nozzle. When properly calibrated, air spreaders can uniformly distribute materials over a wide range of application rates.



**Figure 2.7.5.** Example of air spreader.

## Calibration

Chemical producers may provide information for settings on granular applicators, but these should be used only as a starting point. Manufacturers are as precise as possible with calibration guidelines, but there are several variables that must be measured for accurate calibration. Variables affecting granular application rates are ground speed, swath width and orifice size. Ground speed will vary on hand pushed spreaders based on operator walking differences, so operators should calibrate

spreaders. Swath width depends on the type of spreader, and uniform application of the pesticide is dependent on the operator's ability to maintain constant spacing between swaths. Orifice size is adjusted to distribute a certain amount of pesticide for a given speed and swath width. It cannot be accurately set if the operator does not maintain a nearly constant ground speed and swath width. Since different granules have different flow characteristics, granular applicators must be calibrated for each particular material.

One method for spreader calibration is to apply a known weight of material on a measured area (1,000 square feet for drop or 5,000 square feet for rotary) that is away from fairways or greens, then weigh the remaining material to determine exactly how much was applied. For safety reasons, this method is not recommended, because pesticide may be over applied to an area, causing contamination. A better calibration method is to lift the drive wheel of the spreader and spin it at the proper ground speed (approximately 3 mph) while letting the granules fall on the floor or into a catch pan. This method works well for drop spreaders. The best method is to hang a catch pan under the spreader, push it a known distance, and then weigh the material.

Rotary spreaders may be calibrated by lining up a row of shallow boxes or pans perpendicular to the line of motion (**Figure 2.7.6**). The row should cover 1.5 to 2 times the expected swath width. Put material to be spread in the hopper and make three passes over the boxes operating in the same direction on every pass. The material in each box can be weighed to plot the pattern of the spreader. The effective swath width is determined by the following steps:

**Step 1.** Average three to five center boxes.

**Step 2.** Find the point on each side away from the center where the quantity in a box is half of the average found in step 1.

**Step 3.** Measure the distance from the center of these two boxes for the effective swath width.

If the two boxes used to determine effective swath width do not contain approximately the same amount of material, the pattern is not symmetric and the spreader is performing unsatisfactorily.

## Operation

Where possible, flags can be used to mark the effective swath width to help the operator achieve uniform coverage. If markers cannot be used, operators should focus on an object past the point where they will stop spreading to help make a straight pass.

When operating a spreader with an unacceptable pattern, the operator should reduce the application rate by half and go over the area twice. For best coverage the second passes should be perpendicular from the first passes. Small spreaders were designed to be pushed; unacceptable patterns occur when they are pulled. If conditions exist where the spreader is easier to pull than push, the spreader must be calibrated moving backwards.

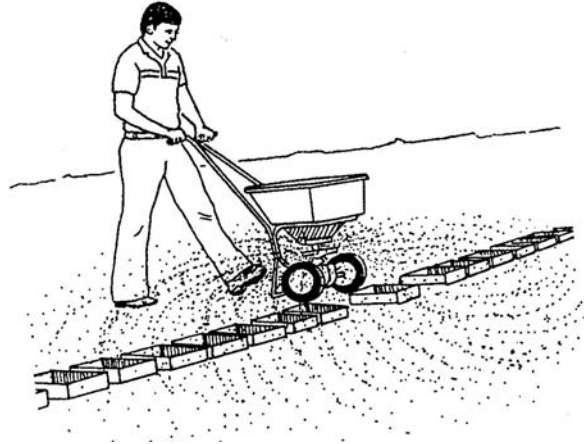

**Figure 2.7.6.** To make a quick pattern check, lay out a row of shallow cardboard boxes in a line perpendicular to the direction of travel.